

5 Gallon Hot Water Machine

Features

5 Gallon Hot Water Machine

- Dispenses up to 18 gallons (68.14 litres) of boiling water (H5X) per hour for food prep and cleaning.
- Precise temperature (72°–212°F) (22.2°C-100°C) ensures consistent, high quality results.
- Locate hot water at preparation site to increase speed, safety and efficiency of kitchen staff.
- Prepare large amounts of mashed potatoes, gravy, cheese sauce, gelatin, oatmeal, and many more foods.
- International electrical configurations available.



Model H5E/H5X*

Dimensions: 28.5"H x 7.1"W x 17.5"D
(72.4cm H x 18.03cm W x 44.5cm D)

For current specification sheets and other information, go to www.bunn.com.

* International models may vary in appearance.

Related Products

Easy Clear® EQHP-10
Product No. : 39000.0004



Easy Clear® EQHP-10L
Product No. : 39000.0001

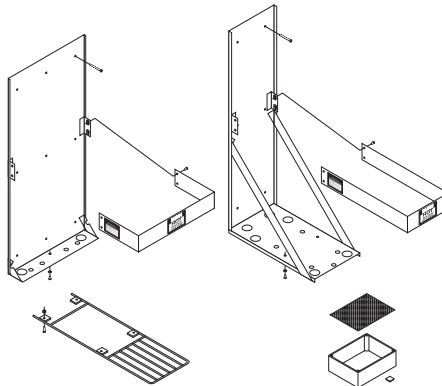

1. Wall Mount Bracket (side)

Product No. : 12542.0000
Dimensions: 30" H x 13 1/2" W x 4 1/2" D
76.2 cm H x 34.29 cm W x 11.43 cm D

2. Wall Mount Bracket (front)

Product No. : 13125.0001
Dimensions: 30 1/2" H x 8 1/2" W x 15 1/4" D
77.47 cm H x 21.59 cm W x 38.74 cm D

3. Container Holding Shelf

Product No. : 12599.0000
Dimensions: 6 3/4" W x 21" D
17.15 cm W x 53.34 cm D

4. Drip Tray

Product No. : 02497.0000

Model

H5E
H5X

Agency Listing



Dimensions & Specifications

Model	Product #	Volts	Amps	Tank Heater Watts	Total Watts	°F Settings	Gal./Hr. cold water input 35°	Gal./Hr. hot water input 140°	Cu. Ft.	Shipping Weight	Cord Attached
H5E-18-120	12500.0020	120	15.4	1800	1850	85/115			4.1 ft ³	32 lbs.	No
H5E-18-120	12500.0033	120	15.4	1800	1850	72			4.1 ft ³	32 lbs.	No
H5E-40-240	12500.0024	240	16.9	4000	4050	200	<i>Varies with application</i>		4.1 ft ³	32 lbs.	No
H5E-40-208	12500.0025	208	19.5	4000	4050	200			4.1 ft ³	32 lbs.	No
H5X-40-240	12500.0026	240	16.9	4000	4050	212	7.3	14.7	4.1 ft ³	32 lbs.	No
H5X-40-208	12500.0027	208	19.5	4000	4050	212	7.3	14.7	4.1 ft ³	32 lbs.	No
H5X-18-120	12500.0028	120	15.4	1800	1850	212	3.7	8.1	4.1 ft ³	32 lbs.	No
H5X-60-208	12500.0032	208	29	6000	6050	212	9.9	18.6	4.1 ft ³	33 lbs.	No
H5M-18-120	12500.0046	120	15.4	1800	1850	200	3.7	8.1	5.6 ft ³	44 lbs.	No

Electrical: All models require 2-wires plus ground service, single-phase. Supplied strain relief on rear side of machine.

Plumbing: 20-90 psi (138-621 kPa). Machine supplied with 1/4" OD male flare fitting.

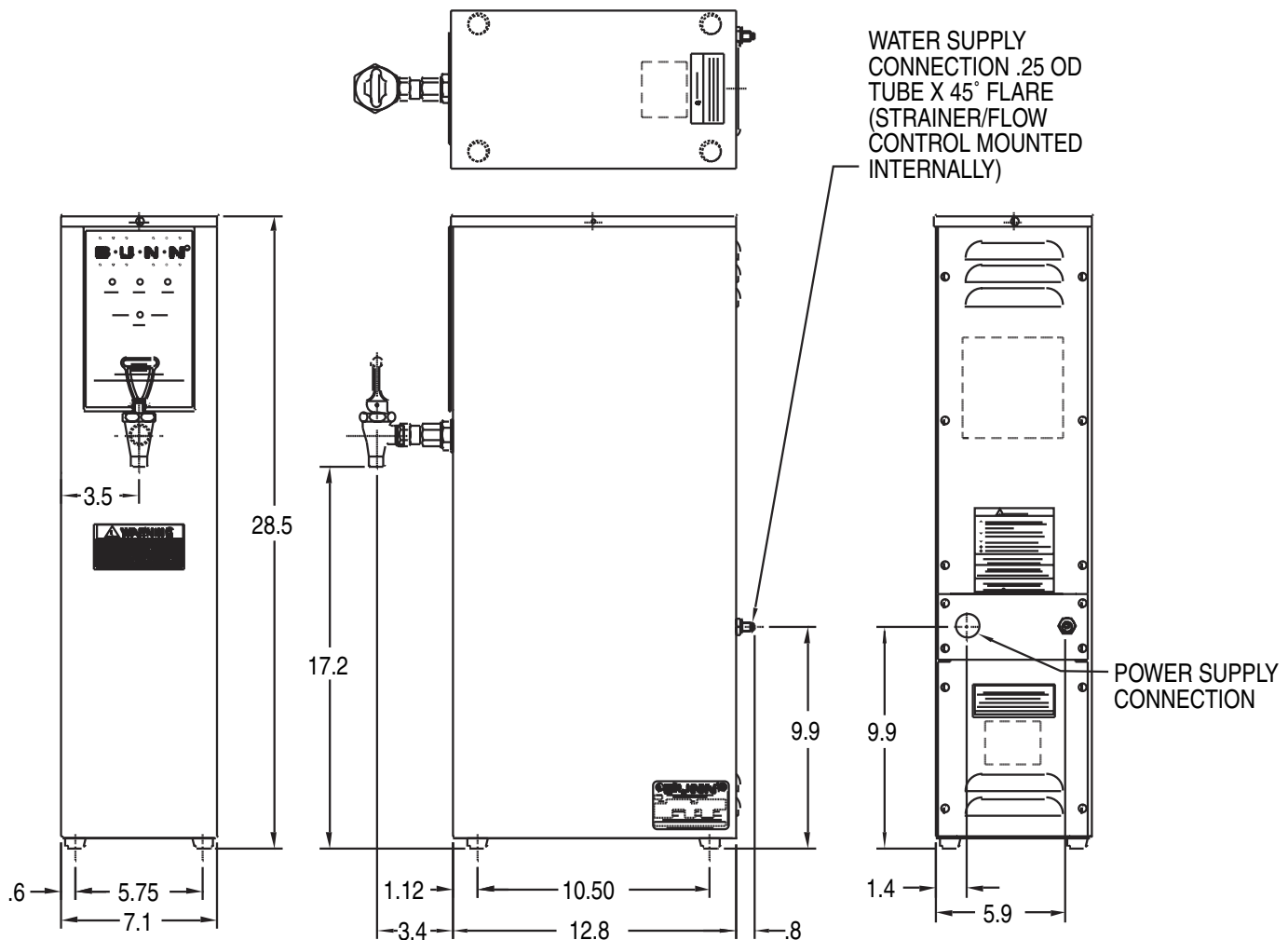

Bunn-O-Matic® Corporation - 1400 Stevenson Drive Springfield, Illinois 62703 • 800-637-8606 • 217-529-6601 • Fax 217-529-6644 • www.bunn.com

BUNN® practices continuous product research and improvement. We reserve the right to change specifications and product design without notice. Such revisions do not entitle the buyer to corresponding changes, improvements, additions or replacements for previously purchased equipment.

All dimensions shown in inches.