

Vertical Contact Toaster



VCT-1000



VCT-1000
with bun feeder



VCT-1000
with mechanical
butter wheel and
bun feeder

The Vertical Contact Toaster model VCT-1000 is designed for contact toasting of buns.

The toaster design allows the operator to place buns on both sides of the heated platen at the same time. Buns are placed into the top of the toaster, and uniform, golden brown, warm buns are then retrieved at the bottom.

The Vertical Contact Toasters are manufactured from the finest materials available and assembled to Roundup's strict quality standards. All units are tested at the factory to ensure dependable trouble-free operation.

Features:

- Bun components – heel, crown, and club sections – are toasted with one setting.
- Easy-to-adjust dial thermostat.
- Space-saving vertical design.
- Continuously moving conveyor allows for immediate toasting.
- 10- to 28-second pass-through time.

Vertical Contact Toaster

Dimensions

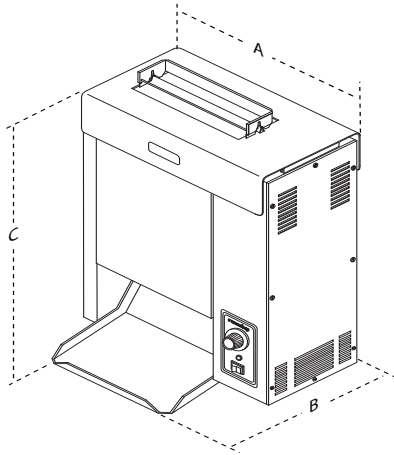

Model & Mfg. No.	Width (A)	Depth (B)	Height (C)
VCT-1000 9210700 9210702 9210704 9210706 9210708 9210710	21 1/4" (540 mm)	15 1/4" (387 mm)	24 1/4" (616 mm)
VCT-1000 9210709 9210714	21 1/4" (540 mm)	15 1/4" (387 mm)	23 1/4" (591 mm)
VCT-1000 9210719	21 1/4" (540 mm)	15 1/4" (387 mm)	29 3/4" (756 mm)

Shipping Dimensions

Model & Mfg. No.	Height	Width	Depth	Weight
VCT-1000 9210719	25" (635 mm)	28" (711 mm)	20" (508 mm)	94 lbs. (43 kg)
VCT-1000 (all other mfg. nos.)	33" (838 mm)	26" (660 mm)	17" (431 mm)	81 lbs. (38 kg)

Electrical Ratings and Plug Configuration

Model & Mfg. No.	Volts	Watts	Amps	Hertz	Plug Description
VCT-1000 9210700	120	1800	15	50/60	NEMA 5-15P 15 Amp., 120 Volt
VCT-1000 9210702	208- 240	2600- 3455	12.5-14.4	50/60	NEMA 6-20P 20 Amp., 250 Volt
VCT-1000 9210704	208- 240	2600- 3455	12.5-14.4	50/60	IEC-309 16 Amp., 250 Volt Pin & Sleeve
VCT-1000 9210706	120	1800	15	50/60	NEMA 5-15P 15 Amp., 120 Volt
VCT-1000 9210708	208- 240	2600- 3455	12.5-14.4	50/60	NEMA 6-20P 20 Amp., 250 Volt
VCT-1000 9210709	208- 240	2600- 3455	12.5-14.4	50/60	NEMA 6-20P 20 Amp., 250 Volt
VCT-1000 9210710	208- 240	2600- 3455	12.5-14.4	50/60	IEC-309 16 Amp., 250 Volt Pin & Sleeve
VCT-1000 9210714	208- 240	2600- 3455	12.5-14.4	50/60	NEMA 6-20P 20 Amp., 250 Volt
VCT-1000 9210719	208- 240	2600- 3455	12.5-14.4	50/60	NEMA 6-20P 20 Amp., 250 Volt

Specifications

Model & Mfg. No.	Pass Through Time
VCT-1000 9210700 9210702 9210704 9210706 9210708 9210710	10 seconds
VCT-1000 9210709	28 seconds
VCT-1000 9210714	17 seconds
VCT-1000 9210719	15 seconds



A.J. Antunes & Co.
We exist to make our customers successful.

A.J. Antunes & Co.
Headquarters/Manufacturing
Carol Stream, Illinois 60188 USA
Phone (630) 784-1000
Toll Free (800) 253-2991
FAX (630) 784-1650

Antunes Equipment
Manufacturing (Suzhou) Ltd.,
Suzhou, Jiangsu, China 215011
Phone: 86-512-6841-3637
Fax: 86-512-6841-3907

P/N 1020230 Rev. F 06/11